

1 1D 1F see details A, B, C

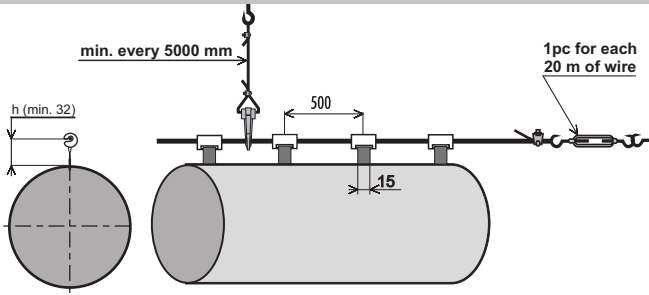

2 2D 2F see details A, B, C

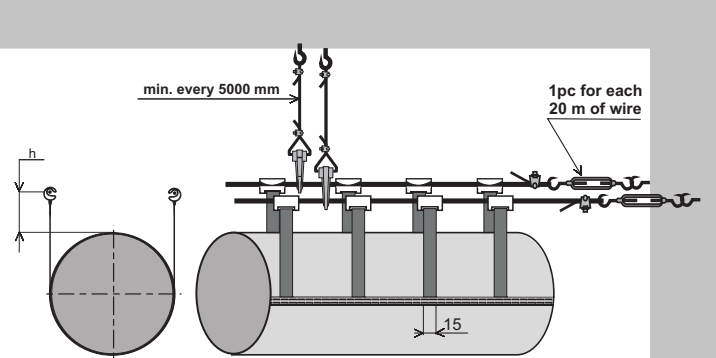

3 see details D, E

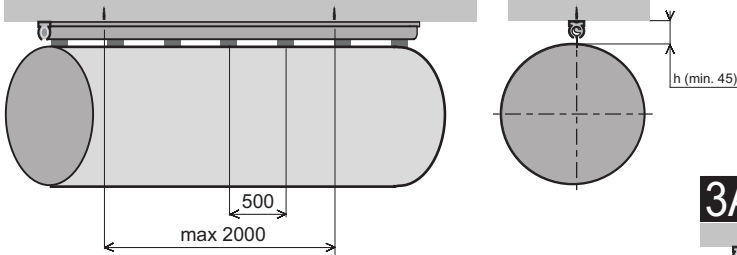

3A see details D, E

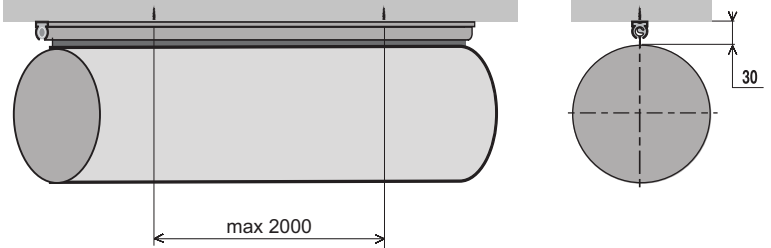

3B see detail H

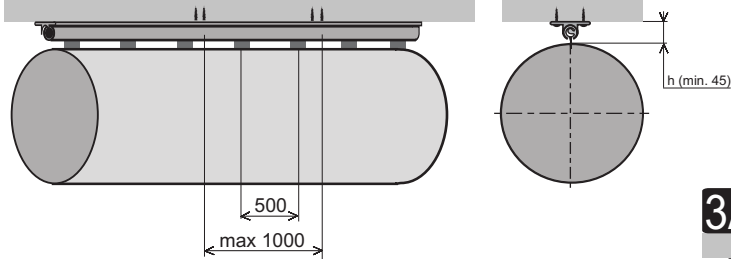

3AB see detail H

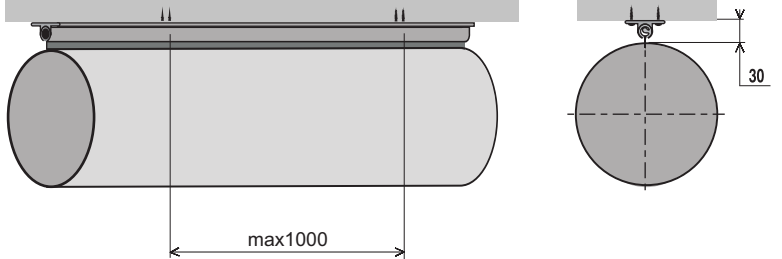

3AC see details J, E

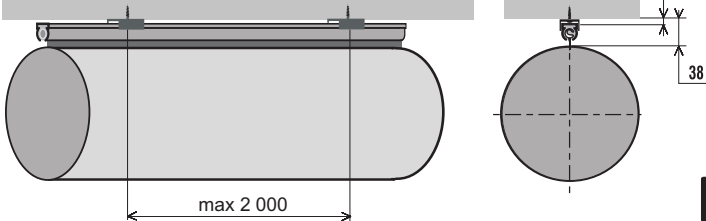

3C see details J, E

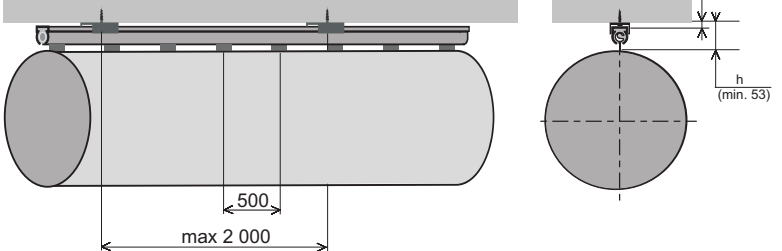

3G see details M,N

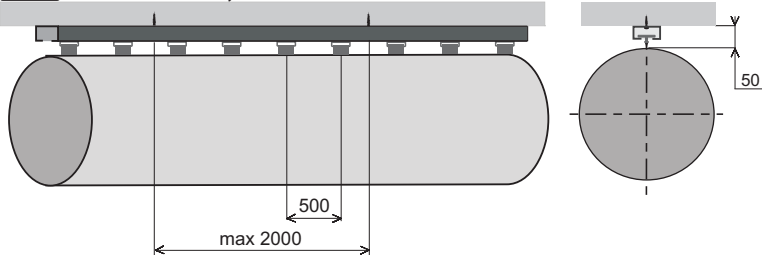

4 see details D, E

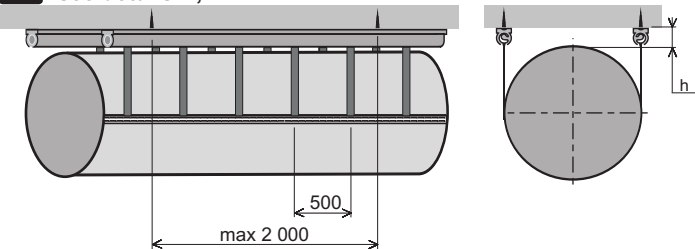

4B see detail H

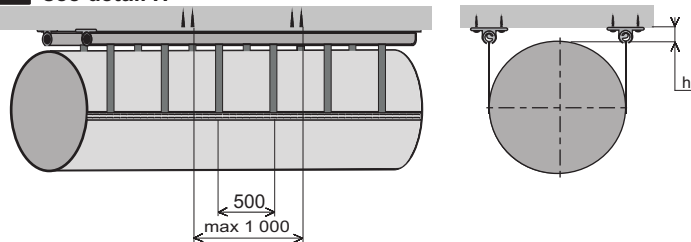

4C see details J, E

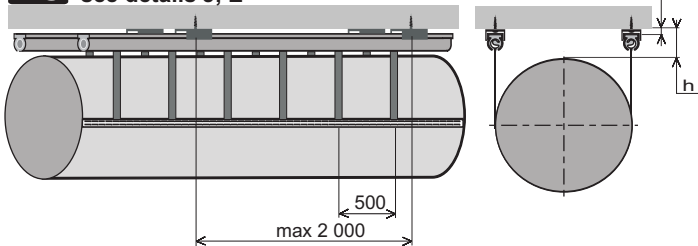

4G see details M, N

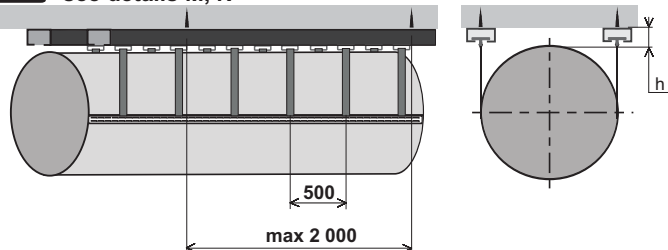

5 5D 5F see details G, E, F, K

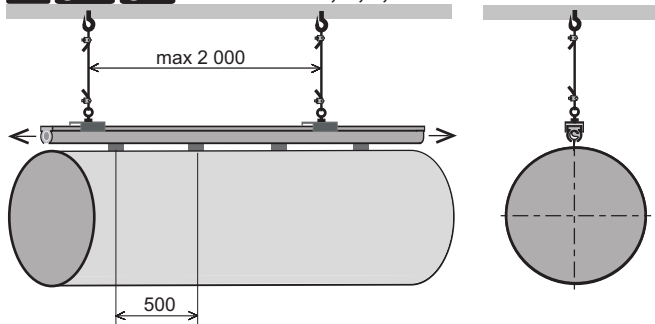

5E see details G, E, F

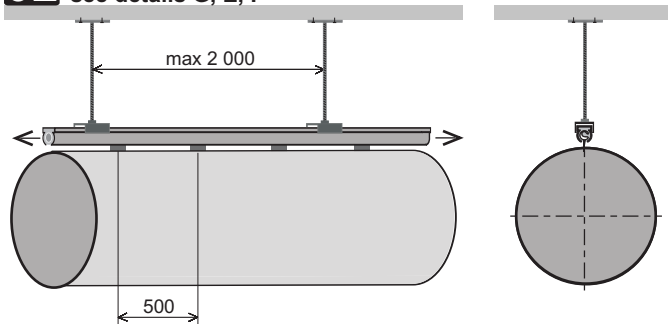

5A 5AD 5AF see details G, E, F, K

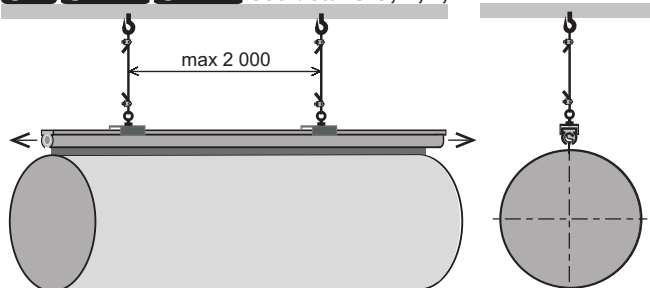

5AE see details G, E, F

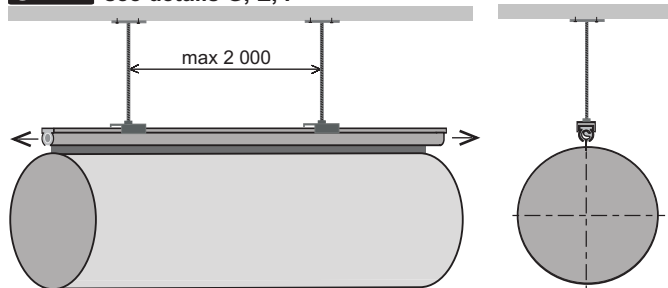

5G see details F, M

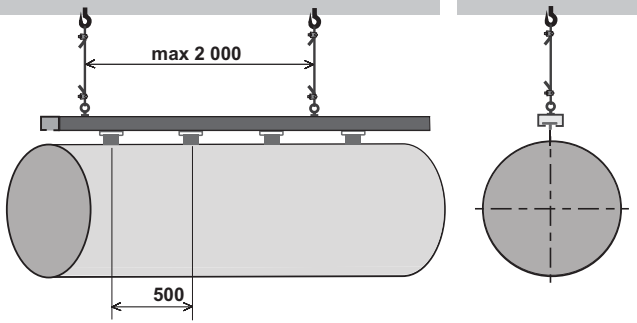

5EG see details F, M

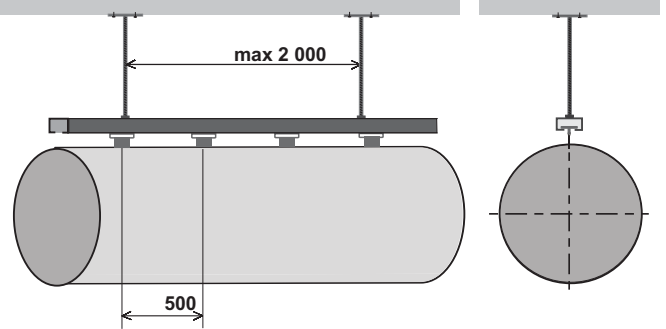

6 6D 6F see details G, E, F, K

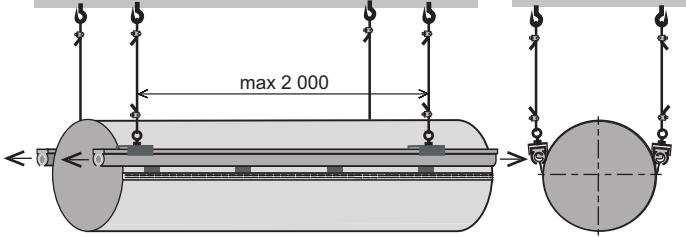

6E see details G, E, F

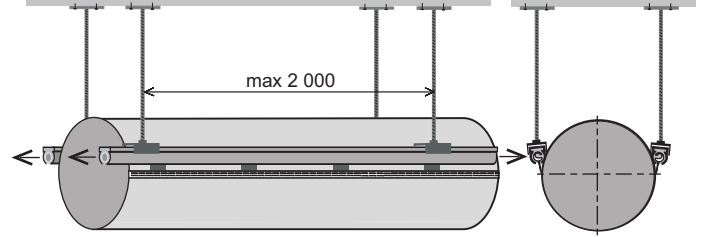

6A 6AD 6AF see details G, E, F, K

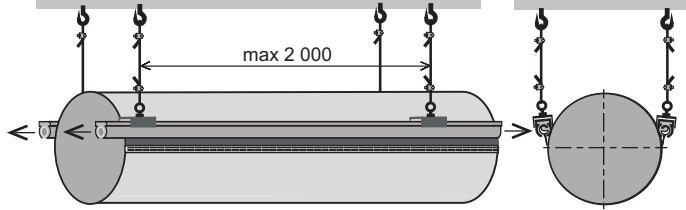

6AE see details G, E, F

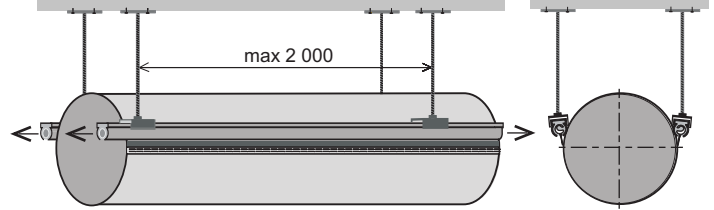

6G see details F, M

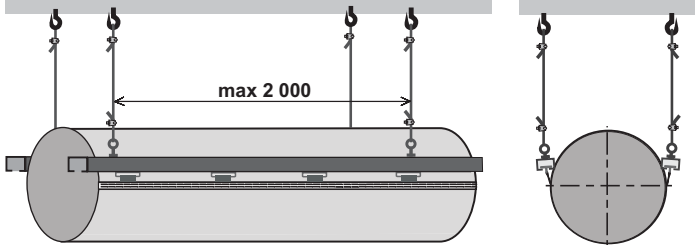

6EG see details F, M

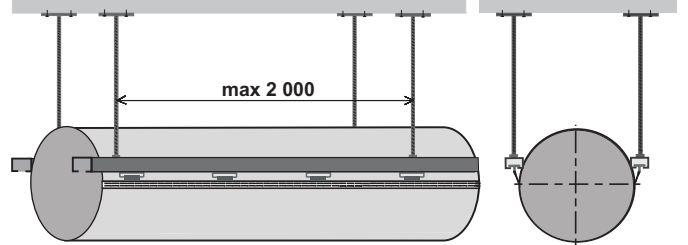

7 7D 7F see detail A

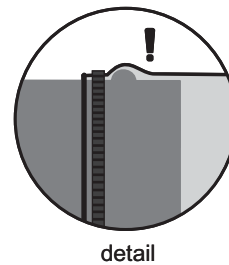
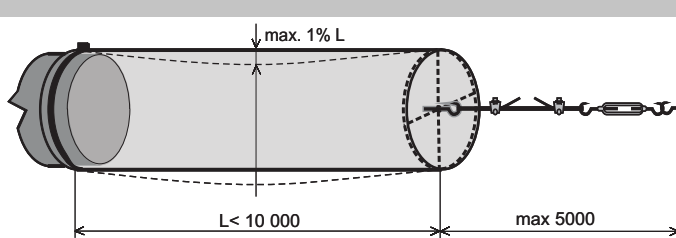

8 see details D, E, I

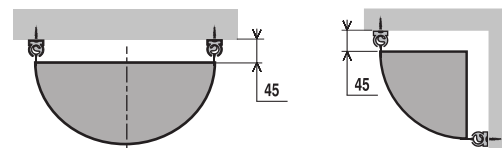
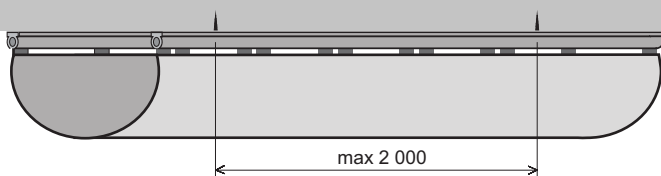

8A see details D, E, I

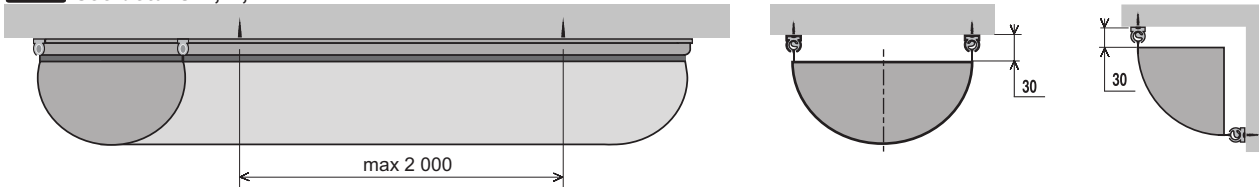

8B see detail H

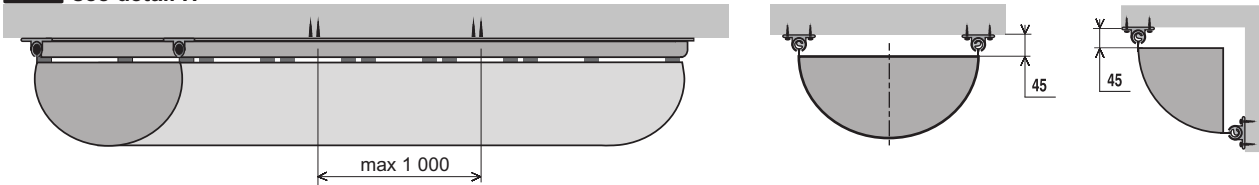

8AB see detail H

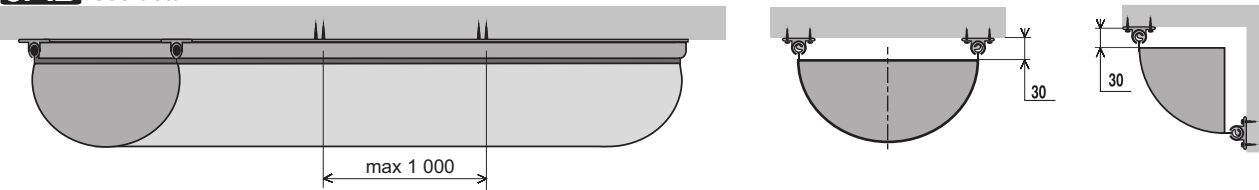

8AC see details J, E

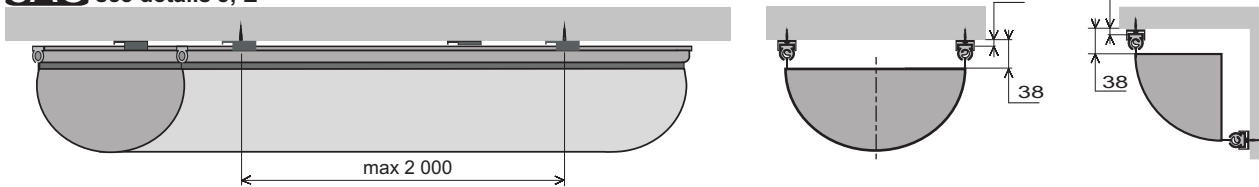

8C see details J, E

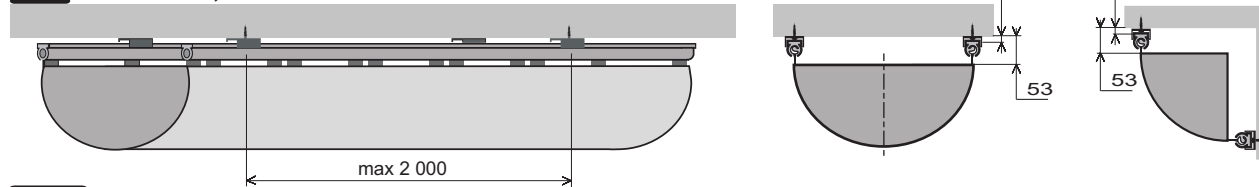

8G see details L, N

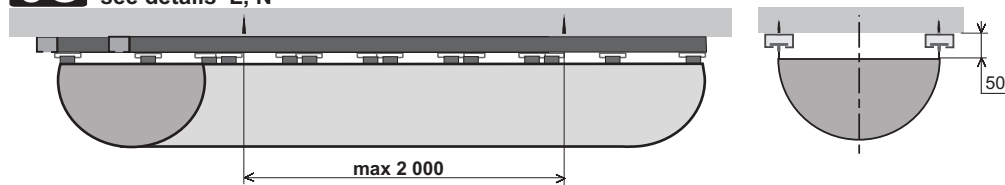

DETAILS

A



B



C



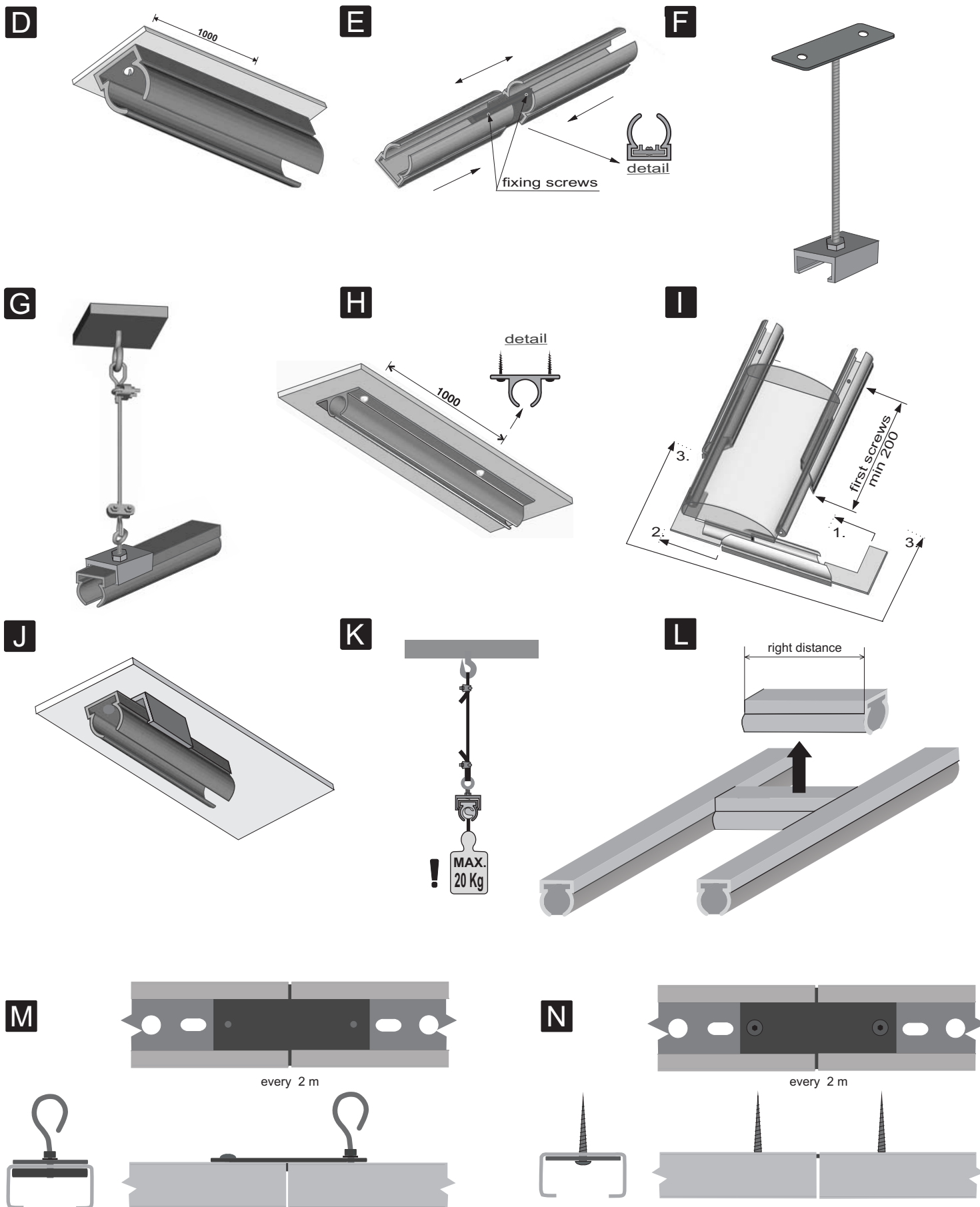

ASSEMBLY

The diffusers must be kept in a tidy place, wrapped. After unwrapping, the diffusers cannot come into contact with dirt. The mechanics must have their hands washed. The diffusers should be installed according to the pictures 1 - 8 C. All the supply part of the air duct must be absolutely clean before the diffuser is inflated for the first time. Do not start up the ventilator until the whole duct is installed. There is a danger that the fabric could be damaged.

Read through all the under-mentioned instructions and think over your concrete conditions. These instructions and the drawing of the concrete installation are parts of every shipment. Look through the drawing and compare it to the marked pictures on two pages A3 format. If there are differences between the drawings, the drawing of the concrete installation is to be used.

RECOMMENDED TECHNIQUE OF INSTALLATION

1

Prepare the mounting material which is not included in the supply:

wall plugs, hooks and screws. The list of the supplied mounting material is attached.

2

Install the diffusers according to the pictures 1 - 8C and according to the drawing of your concrete installation which is attached to the supply.

The technique of your installation is coloured.

3

Other mounting instructions:

- If a special make is not required the standard distance between the upper right side of the duct and the wire is 32 mms.
- for installations 2,4,6,8: horizontal distance between stranded wires or profiles corresponds to a diffuser size
- for installations 1,2,5,6: arrange hangers to required lengths and install them first (there is one wire hanger per every min. 5 m length of wire or every 2 m length of profile)
- for installations 1,2: install turn-buckles in completely open position
- for installations 4,8: a tool with the aid of which you qualify the nominal spacing between the profiles is a part of the supply (see the detail L).

4

Mounting of diffusers to metal conduit or evaporator

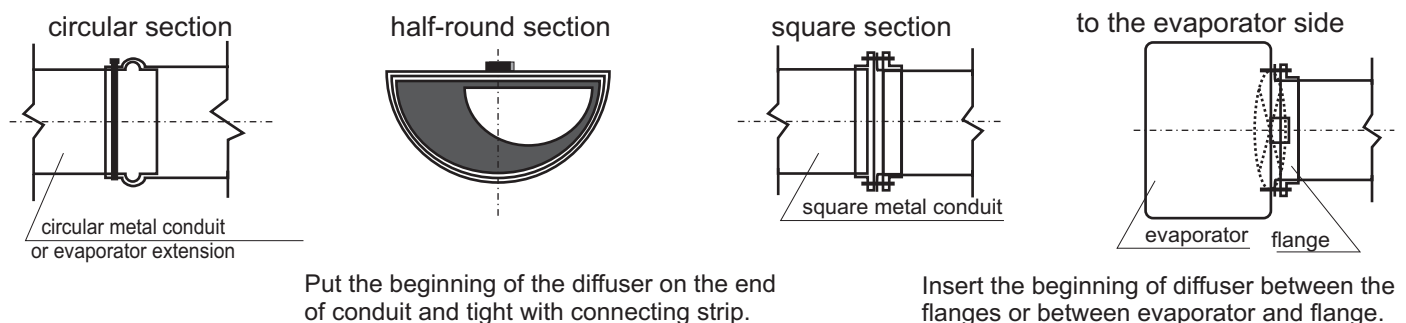

5

Mounting of Membrane diffusers

- connect flap to metal duct or fan. Fix in 4 points by use of thread bar 8 mm and nuts.
- install membrane diffuser on wire or profile. Do not connect with diffuser beginning pre-mounted on flap.
- connect beginning of membrane to the flap bend (open zipper at membrane and put strips on the bend). Use the enclosed small spanner to bring servomotor and flap bend in usefull position.
- fasten zipper between diffuser beginning and next parts of diffuser. The beginning is pre-mounted from producer.

MAINTENANCE

All our diffusers are made of high-quality resistant materials without a natural fibre admixture. The used material is specified when your order is technically processed. The diffusers made of permeable fabric can be washed in a common industrial washing machine. The diffusers with tyres and the ones made of the fabrics NHI, NHE and NMD can be washed manually only.











The process of washing:

Observe the set maintenance symbols of the particular product thoroughly before you wash it. The washing labels are sewn in in the diffusers by the zips.

We recommend:

1. Wash the diffusers with common detergents (dosing according to the directions for use). We advise you to repeat the washing up to four times acc. to level of contamination. A special detergent (we will recommend one by request according to the particular dirt) should be used if the fabric is badly soiled.
2. Desinfect the diffusers only if essential in conformity with the technology used in the place where the diffusers are installed. Use special desinfectants, observe the manufacturer's recommended method of desinfection.
3. Rinse the diffusers in clean water.
4. Spin-dry the diffusers gently, install them and finish drying by the air flow from the ventilator.

Symbols key:

	max. temperature for washing 40°C normal mechanical action normal rinsing normal separating
	gentle washing in a washing machine, maximum temperature 40 °C, gentle mechanical action, rinsing in water cooling down, gentle spin-driing
	washing only by hands product must not be washed in washing machine max. temperature 40°C cautious handling
	ironing within of max. temperature of ironing surface 110°C, cautious with steam ironing
	product must not be ironed steaming is inadmissible
	dry in a drum-drying machine use lower temperature of drying
	product can't be dryed in a drum-drying
	product must not be dry cleaned the stains must not be removed by organic solvents
	product can be dry cleaned with tetrachlorethen, monofluortrichlormethan and all solvents mentioned with symbol F usual cleaning progresses are without any limits
	product must not be whitenned with detergents disengaged chlorine